

# UL 508 Application Guide

UL 98 vs. UL 508: Selecting the  
Right Switch for the Right  
Application

June 2008  
UL 508 Application Guide



Make the most of  
your energy<sup>SM</sup>.



# Introduction: What's the confusion about?

## NEC 430.108

“Every disconnecting means in the motor circuit between the point of attachment to the feeder or branch circuit and the point of connection to the motor shall comply with the requirements of 430.109 and 430.110”

## NEC 430.109

### (A) General

- (1) **Motor Circuit Switch** – “rated in horsepower”
- (2) **Molded Case Circuit Breaker**
- (3) **Molded Case Switch**
- (4) **Instantaneous Trip Circuit Breaker** – “that is part of a listed combination motor controller”
- (5) **Self Protected Combination Controller**
- (6) **Manual Motor Controller** – “additionally marked “Suitable for Use as Motor Disconnect”

UL98

UL508

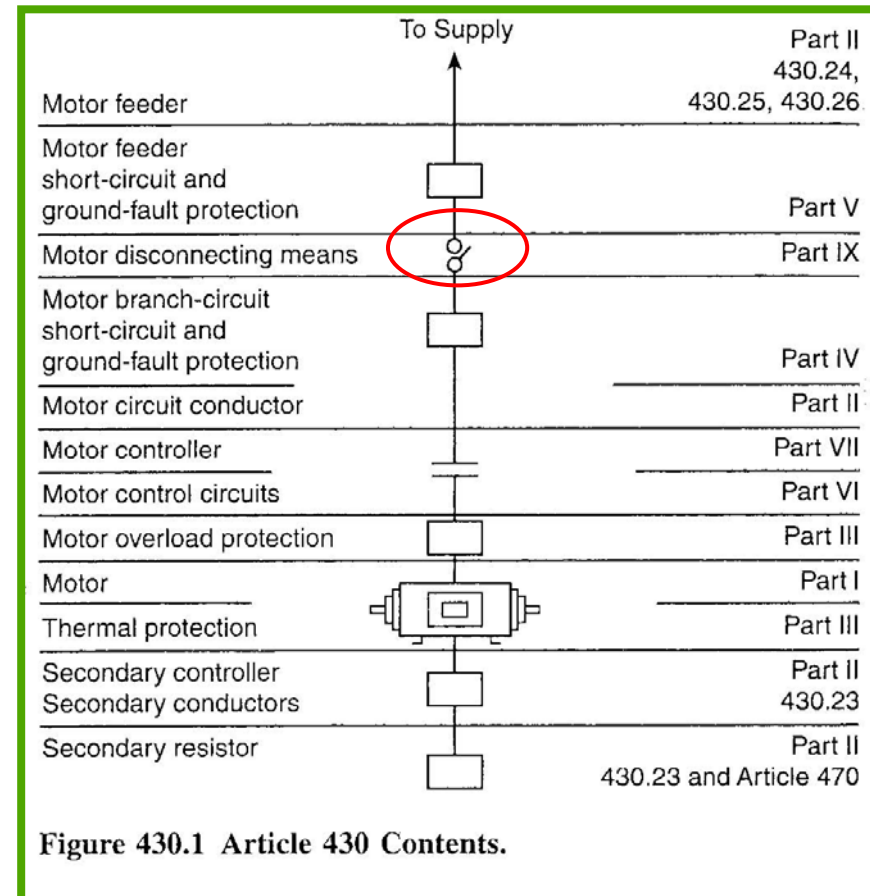

# Introduction: What's the confusion about?

- **NEC 430.102(A)**

“An individual disconnecting means shall be provided for each controller and shall disconnect the controller. The disconnecting means shall be located in sight from the controller location”

- **NEC 430.102(B)(2)**

“The controller disconnecting means (430.102(A)) shall be permitted to serve as motor disconnect if it is in sight from the motor location and the driven machinery location.

Below is only needed when controller disconnecting means is not in line of sight or greater than 50 feet.

- **NEC 430.102(B)(1)**

“A disconnecting means shall be located in sight from the motor and the driven machinery location”

## Exceptions:

- Where impracticable or introduces additional hazard
- Industrial installations where only qualified personnel service the equipment

To Supply

Motor  
Disconnecting  
Means

Motor Branch  
Short Circuit And  
Ground  
Fault  
Protection (SCPD)

Controller

Overload

“Sight”  
Disconnecting  
Means

Motor

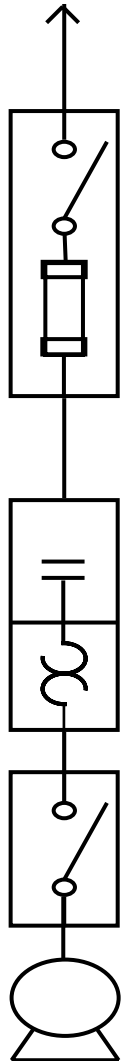

# Introduction: What's the confusion about?

- **NEC 430.109(6) Manual Motor Controller**
  - Additionally marked “Suitable as Motor Disconnect” shall be permitted as a disconnecting means where installed between the final motor branch circuit short circuit protective device and the motor.

## NOTE:

NOT all UL508 Manual Motor Controllers are marked “Suitable as Motor Disconnect”

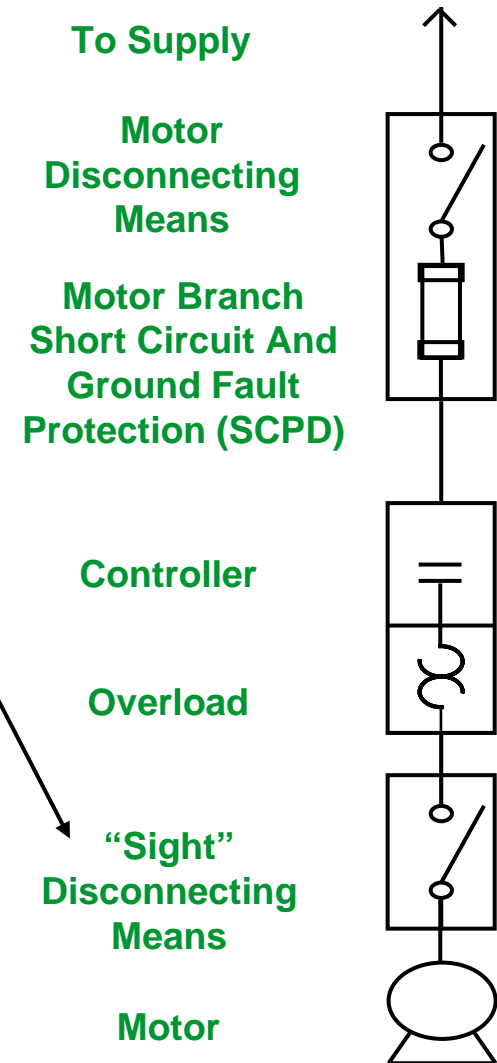

# Introduction: What's the confusion about?

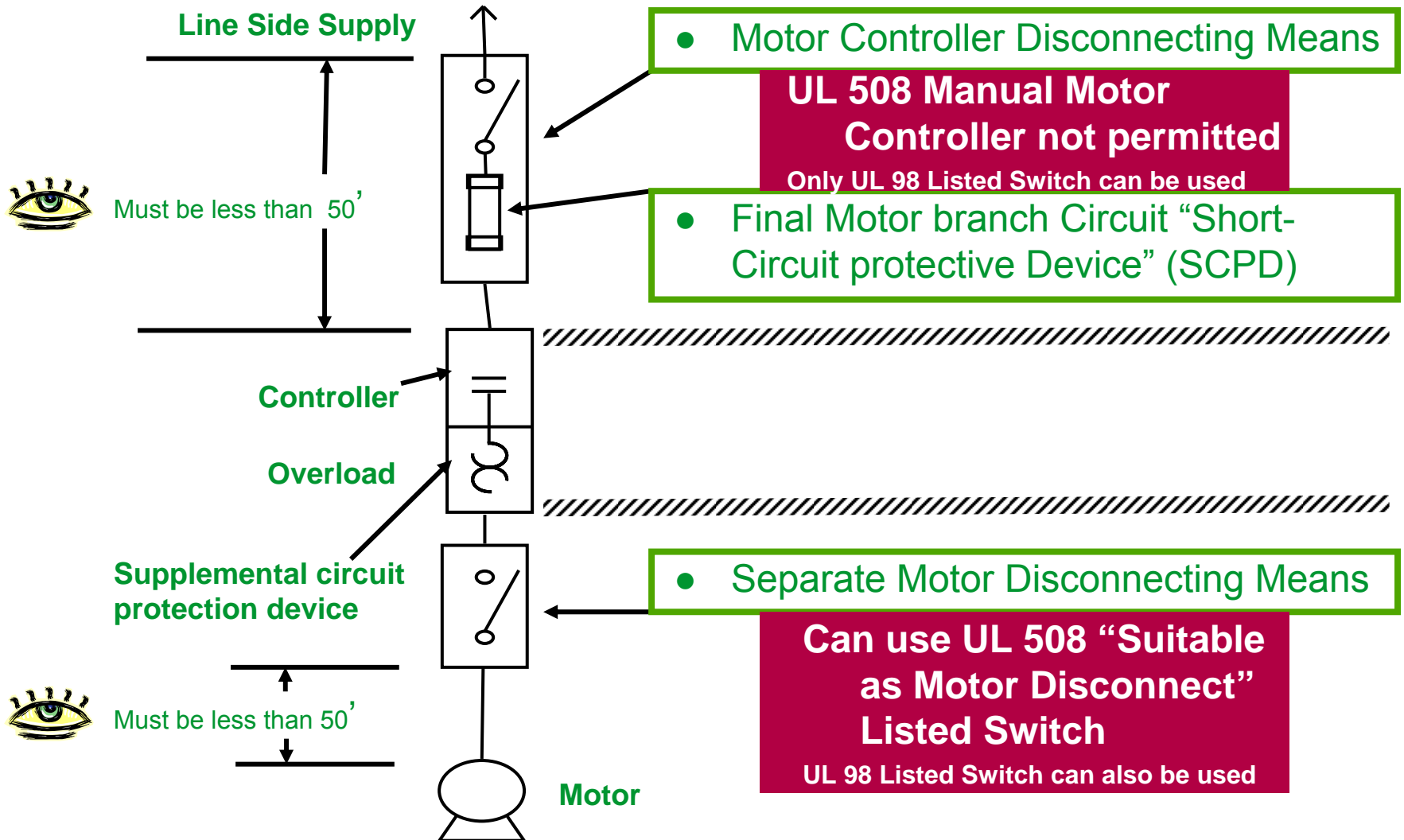

# Introduction: What do I use and when?

## UL98 Heavy Duty Safety Switches



## UL508 Manual Motor Controllers



### UL 98 HDSS - Applications

Service Entrances

Individually mounted circuit protection device

Type 1, 3R, 4X, 7, 9 and 12

NEC 430.109(6) Line of Sight Disconnect

### UL 508 - Applications

NO

NO

Type 1, 3R, 4X, and 12

NEC 430.109(6) Line of Sight Disconnect

**When in doubt, install a UL 98 Safety Switch**

# Standards Comparison: UL 98 vs. UL 508

## UL Requirements

### UL 98

#### Motor Circuit Switch:

UL 98: Enclosed & Dead Front Switches – all encompassing standard for switches used in general application.

- Distribution – current rated
- Motor Disconnect - HP Rated

### UL 508

#### Motor Disconnect:

UL 508: Industrial Control Equipment Motor Controller/Motor Disconnect – HP Rated

# Standards Comparison: UL 98 vs. UL 508

	UL 98 Motor Circuit Switch	UL 508 Manual Motor Controllers
Temperature Test	115% of current @ max FLC = HP	100% current
Overload Test	50 cycles @ 1 cycle/10 sec (<100HP)	50 cycles @ 1 cycle/10 sec
Endurance Test (30 -100A)	6,000 w/ current & 4,000 w/o current @ 6 ops/min	6,000 w/ current & 4,000 w/o current @ 6 ops/min
Endurance Test (200A)	6,000 w/ current & 2,000 w/o current @ 5 ops/min	6,000 w/ current & 2,000 w/o current @ 5 ops/min
Dielectric Voltage Withstand Test	Test between line and load terminals with switch open @ 1000V plus twice rated voltage	Test between line and load terminals with switch open @ 1000V plus twice rated voltage
Short Circuit Test	Welding of Contacts: Not Permitted	Welding of Contacts: Not Permitted
Short Circuit Test	Short Circuit Rating: Up to 200K	Short Circuit Rating: Up to 10K
Short Circuit Test	Systems Tested: 10, 2W; 20, 4W; 30, 3W	Systems Tested: 30, 3 pole & 10, 1 pole

# Product Differences: UL 98

- 30 – 1200A type 1, 3R, 4/4X, 12 enclosed 30-1200A not enclosed (for OEM use)
- Fusible & Not-fusible
- 200K AIR Max.
- Full Distribution line to line spacing
- Unlimited application range Current and Horsepower rated
- Pad lockable in the OFF or ON position. Door interlock allows access in either ON or OFF position and authorized operation in all positions. (required by NFPA 79)
- Generous wiring space

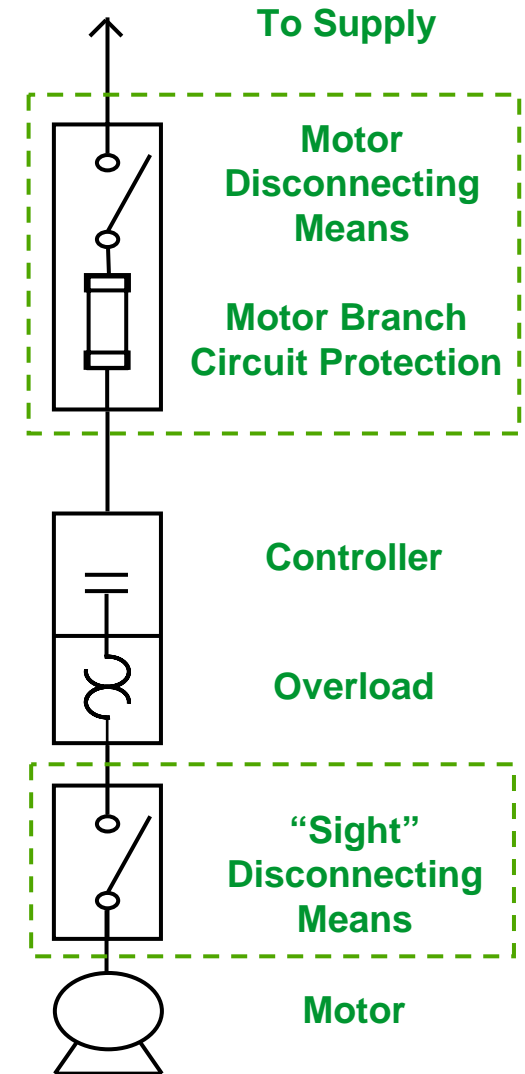

# Product Differences: UL 508

- Type 1, 4/4X & 12 Enclosed
- UL 508 Switch not enclosed (for OEM use)
- Not-fusible
- Non-metallic & Stainless steel enclosures
- 10K AIR Max
- Control Equip. Line to Line Spacing
- Limited application - Must be applied on the load side of the branch circuit over current device
- Horsepower rated
- Pad lockable in the off position. The cover can only be removed when the switch is in the ON position. This prevents turning the switch ON with the cover removed but permits the switch to be on for troubleshooting.

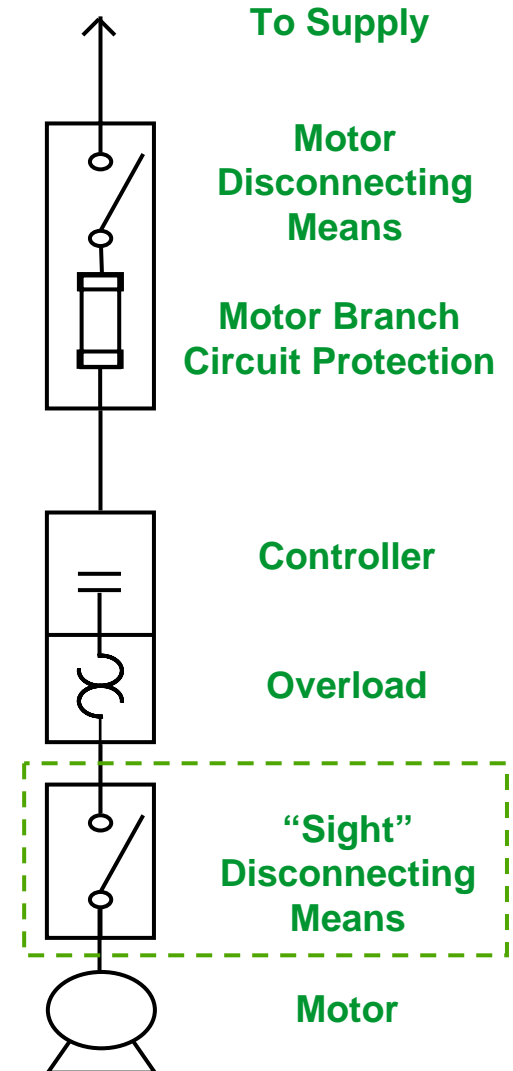

# Proper Application: Service Disconnect



- **NEC 225.31 Disconnecting Means**

Means shall be provided for disconnecting all ungrounded conductors that supply or pass through the building structure.

- **NEC 225.36 Suitable for Use as Service Equipment**

The disconnecting means specified in 225.31 shall be suitable for use as service equipment.

**Circuit breaker  
UL 489**

**Use Enclosed Switch  
UL 98**

**Manual Motor  
Controller UL 508**



# Proper Application: Individually Mounted Circuit Breaker



- **NEC 240.40 Disconnecting Means for Fuses**

A disconnecting means shall be provided on the supply side of all fuses over 150 volts to ground and cartridge fuses of any voltage where accessible to other than qualified persons so that each individual circuit containing fuses can be independently disconnected from the source of power.

**Circuit breaker  
UL 489**

**Use Enclosed Switch  
UL 98**

**Manual Motor  
Controller UL 508**



# Proper Application: Service Disconnect



- **NEC 430.102(B)**

“A disconnecting means shall be located in sight from the motor and the driven machinery location”

- **Exceptions:**

- Where impracticable or introduces additional hazard
- Industrial installations where only qualified personnel service the equipment

**Can use either a UL 98 or UL 508**

**Enclosed Switch  
UL 98**

**Manual Motor  
Controller UL 508**

# Proper Application: Safety

## • NEC 110.10

The over current protective devices, the total impedance, the component short circuit current ratings and other characteristics of the circuit to be protected shall be selected and coordinated to permit the circuit protective devices used to clear a fault to do so without extensive damage to the electrical components of the circuit.

For use with Motor Disconnect - Max. AIR of 10,000A

	Max Available Short Circuit Current at Point A		
	240V 1Ø	240V 3Ø	480V 3Ø
30A OCPD, #10	200KA	200KA	43.4KA
60A OCPD, #6	31.6KA	20.7KA	12.1KA
100A OCPD, #3	13.4KA	12.7KA	11KA

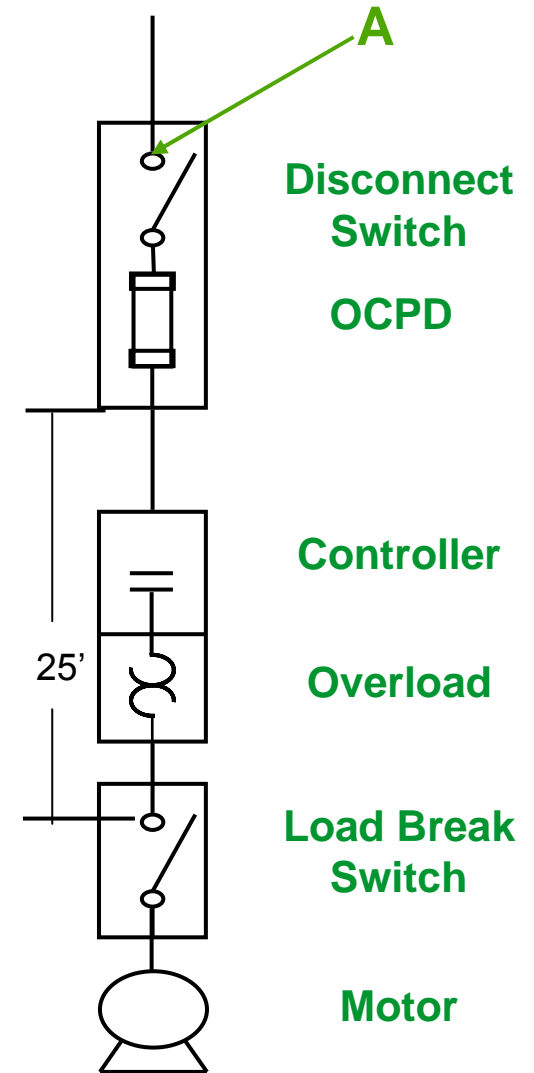

Must be 25' conductor in place

# Conclusion: Common Misapplications

1. UL508 Listed Manual Motor Controller not marked “Suitable As Motor Disconnect” **used as motor or branch disconnect**
2. UL508 Listed Manual Motor Controller marked as “Suitable As Motor Disconnect” **used as branch disconnect**
3. UL508 Listed Manual Motor Controller marked as “Suitable As Motor Disconnect” **used for non motor applications**  
(Example: Welders, heaters, ovens, etc.)

**Still Confused which to install in your application...**

**When in doubt, install a UL 98 safety switch.**